

VACUUM COLLECTOR

Technical Specifications

Type	V15	V20
Collector Surface	1,74m ²	2,32m ²
Aperture Surface	1,57m ²	2,10m ²
Number of vacuum tubes	15	20
External Dimensions	1,08 x1,61m	1,44 x1,61m
Weight	40	53
Glass tube external diameter	47mm	
Glass tube length	1500mm	
Cover material	Borosilicate glass 3.3	
Cover thickness	1,5mm	
Vacuum	p<0,005Pa	
Casing material	Aluminum	
Diameter of connections	22mm	
Thermal insulation thickness of header	30mm	
Insulation material of header	P.U. foam 45 kg/m ³ and fiberglass	
Absorber Material	Inner copper U-PIPES / D=9,52 thickness 0,65mm Inner aluminum fin /thickness 0,80mm	
Absorber coating	Sputtering selective surface	
Absorption (α)	a>0.93	
Emissivity (ϵ)	$\epsilon < 0.06$	
Absorbing surface glass tube diameter	33mm	
Heat transfer	Glycol solution	
Output (Wurzburg-Germany)	>640 kWh/m ² /year	
Max. working pressure	10 bar	
Max. working temperature	220°C	

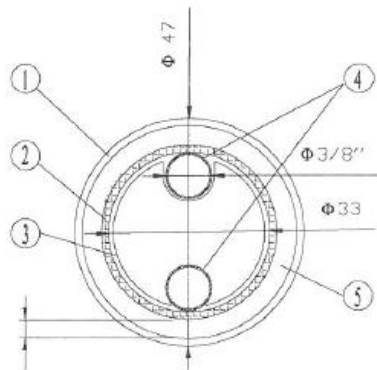

1. Outer glass
2. Inner glass
3. Aluminum fin
4. Copper tube in U-form
5. Vacuum



SOLE S.A.

Lefktron 1 & Laikon Agonon
13671 - Acharnai, Athens, Greece

Phone:
+30 210 2389500

FAX:
+30 210 2389502

email:
export@sole.gr

<http://www.eurostar-solar.com>